

ArchitectECA2030

SC 3 Demo 3.1 Key Card

Road Condition Detection and V2X connectivity (RCD-V2X)

ArchitectECA2030



Main aim						
<ul style="list-style-type: none"> Detect road condition and fusion the data for V2X communication. Sensor model and prototype for road conditions and friction evaluation. On board unit (OBU) for information fusion and connectivity. Experimental set-up suitable for investigations of residual risks of systems and subsystems used to build the sensors and connectivity functions. 						
Partner	SINTEF, NXT, TSENSE					
ECS value chain	Research / Tier 1					
State-of-the-art			Beyond SotA / Innovation		Targeted TRL	
<ul style="list-style-type: none"> Autonomous driving technology transition from fail-safe, fail-aware to fail-operational and fail-prediction systems addressing predictive safety for dealing with security-safety issues. Safety is related to the environment conditions. Limited capabilities of autonomous vehicles to communicate with other vehicles, and infrastructure about overall operations, missions, and road conditions. Road surface conditions monitoring systems today are not part of automotive sensor suits. Limited technology and methods to assess and mitigate the effects of varying surface conditions. Limited interaction between the perception domain and the connectivity domain. 			<ul style="list-style-type: none"> Integration/interaction of the V2X connectivity and the perception for road conditions. Perform tests for the evaluation of residual risk that are aligned with the standard framework and use it as input to the methodology for risk estimations of connectivity systems. Support virtual validation of automated and connected vehicles. 		TRL 4	
Link to project objectives						
Objective	Addressed (Y/N)		How			
O1 – Continuous robust design optimization for each part in the ECS value chain	Y		Road condition detection and V2X connectivity will be demonstrated in real surroundings in the Fredrikstad area. That is a robust and secure road surface conditions monitoring system including vehicle sensor arrays, AI/edge computing capabilities, communication internally in the vehicle, to other vehicles at defined distanced, and the road infrastructure. The sensor arrays, computing capabilities, and communication properties are optimised for the applications to be demonstrated.			
O2 – Framework for safety validation of ECS value chain	Y		As part of the framework, both functional and non-functional requirements (FR, NFR) are defined, together with key performance indicators (KPIs) for verification and validation the demonstrator components, subsystem, and system.			
O3 – Identification & management of residual risks over the entire ECS value chain	N		N.A.			
O4 – End-user acceptance by trustworthy ECS value chain	Y		The road surface conditions monitoring system is trustworthy if the residual risk is minimized and end-users can rely on system and its safety functions (information, warnings, and actions). Through this sub-supply chain, we want to demonstrate the ability to perform specified functions while following a set of stated design principles for optimization and acting in the best interests of the end-users.			
O5 – Zero emissions, zero crashes, zero congestions by ECA2030-car	Y		A monitoring system that provides real-time information on the road conditions in which the vehicle is located at all times is of great value in terms of avoiding accidents and reduce congestions.			
Joint demonstrator (JDEM3)			Linked supply chains (Y/N)		Considered MonDev layers	
DEM3.1		DEM3.2	SC1	N	System (S)	Y
			SC2	N	Subsystem (SS)	Y
			SC3	Y	Component (C)	Y
			SC4	N	Subcomponent (SC)	Y

Setup

An overview of the block schematic is illustrated below (left). The demonstrator will provide a V2X connectivity system together with the technology and methods to assess and mitigate the effects of varying road surface conditions. The activities will address the interaction between the perception domain (cameras, sensors, etc.) and the connectivity domain (V2X, etc.), together with the quantification of uncertainty and residual risk calculation. The demonstrator collaborated partners are TSENSE, NXT and SINTEF, and their different roles are illustrated below (right).

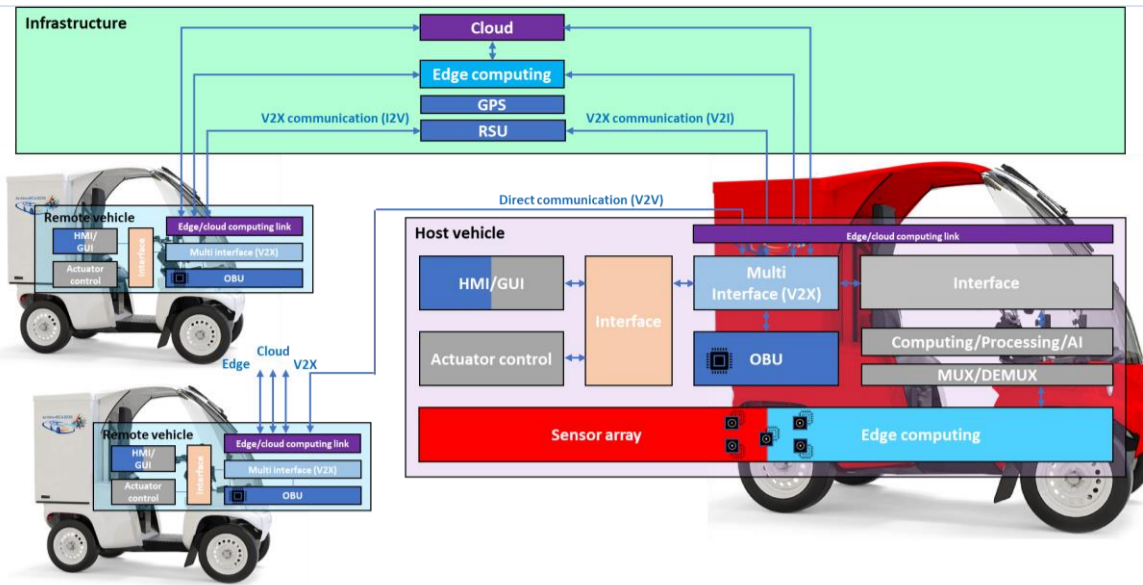

Block schematic overview

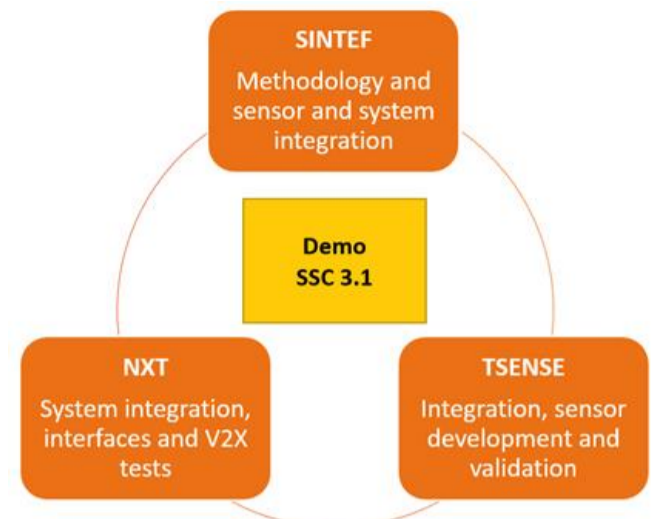

Cooperation and roles

Benchmark scenario/mission/etc.

Detect road condition and fusion the data for V2X communication. Sensor model and prototype for road conditions and friction evaluation. On board unit (OBU) for information fusion and connectivity. Experimental set-up suitable for investigations of residual risks of systems and subsystems used to build the sensors and connectivity functions.

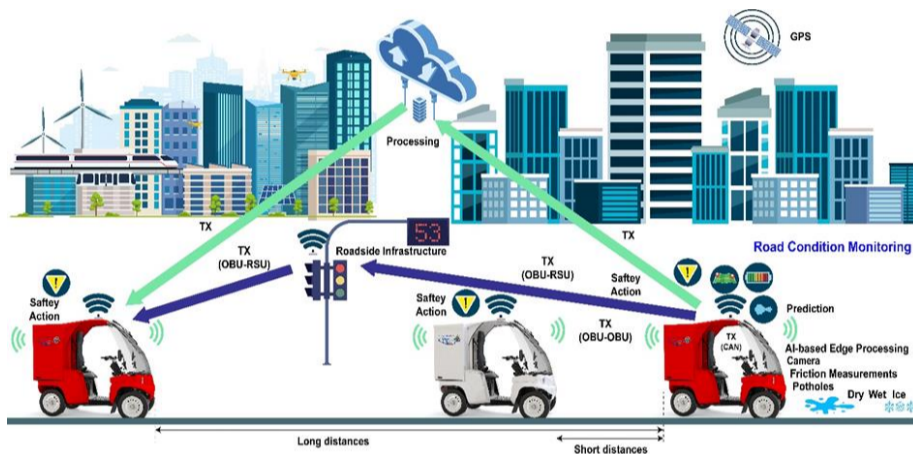

Demonstrator overview

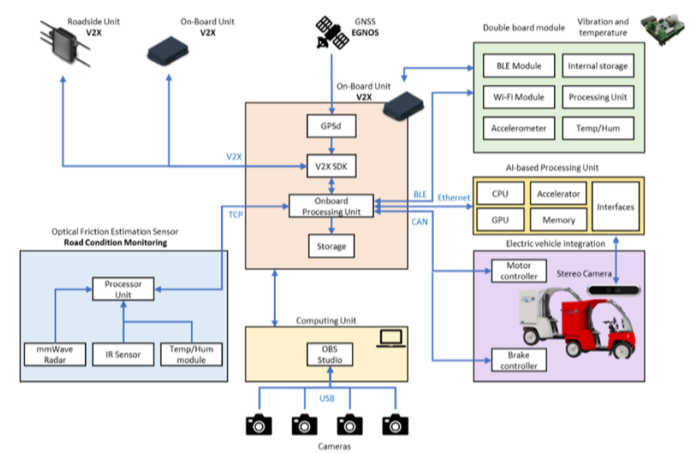

KPIs (related to requirements)

- Road surface pattern recognition.
- Road friction prediction.
- Communication redundancy.

Baseline

- Distinguish between three types of road surfaces, (accuracy $\geq 70\%$ for each type of road surface).
- Deviation between real braking distance and predicted/ calculated braking distance should be less than 30%.
- Two different communication channels for redundancy of information (e.g., V2X and Cellular), and that the functionality is maintained even if one of the channels fails.

Evaluation

Evaluation platform – simulation, driving simulator, etc.

Current status/demonstration

- Identify the residual risk related to the functional requirements defined and identify a methodology for residual risk assessment.
- Equip the vehicles with vibration, temperature, humidity sensors and cameras for monitoring the driving conditions in different scenarios and considering different road and weather conditions.
- Integration of the first generation the road surface condition sensor into the vehicle and preliminary tests.
- Results, plots, evaluated KPIs, meet requirements, videos, etc.
- Integration of the second generation the road surface condition sensor into the vehicle and run the validation and test.
- Evaluate the next generation road surface condition sensor.

Impact

Integration/interaction of the V2X connectivity and the perception for road conditions. Perform validation for the evaluation of residual risk that are aligned with a validation framework and use it as input to the methodology for risk estimations of connectivity systems to support virtual validation of automated and connected vehicles.

Used standards

- **ISO/PAS 21448:** Road vehicles - Safety of the intended functionality (SOTIF).
- **ISO 26262:** Road vehicles - Functional safety.

Future standardization potentials

- *Holistic approach by combining the existing standards and addressing the identified gaps in the next standardisation activities:*
 - **ISO 26262**
 - **ISO/PAS 21448**

- | | |
|---|---|
| <ul style="list-style-type: none"> • IEC 61508: Functional safety of electrical/ electronic/ programmable electronic safety-related systems. • IEEE 802.11p: IEEE Standard for Information technology -- Local and metropolitan area networks -- Specific requirements -- Part 11: Wireless LAN Medium Access Control (MAC) and Physical Layer (PHY) Specifications. Amendment 6: Wireless Access in Vehicular Environments. • IEEE 802.11bd: Standard for Information technology-- Telecommunications and information exchange between systems Local and metropolitan area networks--Specific requirements - Part 11: Wireless LAN Medium Access Control (MAC) and Physical Layer (PHY) Specifications. Amendment: Enhancements for Next Generation V2X. • ISO/TR 4804: Road vehicles - Safety and cybersecurity for automated driving systems - Design, verification, and validation. • ANSI/UL 4600: Standard for Evaluation of Autonomous Products. | <ul style="list-style-type: none"> ○ IEEE 802.11p -> IEEE 802.11bd ○ ISO TR 4804 -> ISO/AWI TS 5083 |
|---|---|